

TRAIN SMARTER[™]



FREIGHT | TRANSIT | DIGITAL

THE GLOBAL STANDARD FOR WAGON MOBILITY

Amsted Rail® is a leading global provider of integrated freight wagon component systems, produced with precision, to deliver best-in-class value to our customers for freight, transit and locomotive assets. Amsted Rail is also at the forefront in delivering IoT telematics solutions that track, trace and monitor fleet assets 24/7 virtually anywhere around the globe.

For over a century, Amsted Rail has leveraged the power of innovation to create high performance solutions that are helping reimagine the future of mobility. We're relentless in our pursuit of new product advances, new engineering technologies and new manufacturing processes to better prepare our customers for the challenges ahead.

Assisting our customers across the globe

With manufacturing facilities spanning over 50 locations across six continents, no one can match Amsted Rail's commitment to performance, safety and responsiveness. Today, we are expanding our footprint by investing in major heavy haul markets to partner with customers looking to increase reliability and performance of their rail assets.

Innovation is at the heart of our culture

Through our state-of-the-art manufacturing processes, Amsted Rail continues to redefine industry standards for innovation and technology. Each product is precision-engineered, built to the tightest tolerances, and rigorously tested to simulate real-world conditions. We have continued to introduce new product innovations that are tuned to support each market and its unique operating conditions

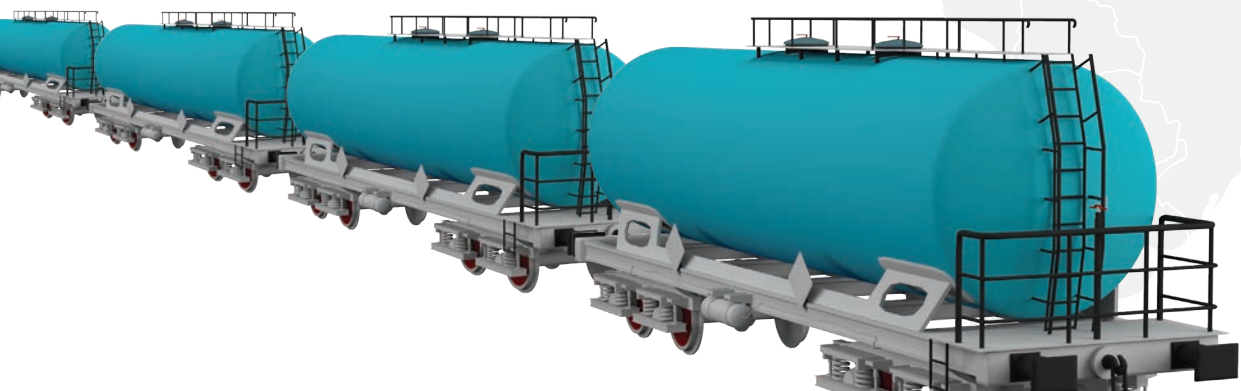



OUR MISSION

To improve the safety, reliability and efficiency of railways.



OUR VISION

To be the global leader of innovative, integrated, fully assembled rail undercarriage and end-of-car systems.



OUR VALUES

- ▶ Act safely above all else
- ▶ Show passion for the customer
- ▶ Operate with dignity & respect
- ▶ Choose world-class over great
- ▶ Embed an ownership mentality

Amsted Rail

LEADING THE WAY IN FULLY INTEGRATED FREIGHT CAR SYSTEMS

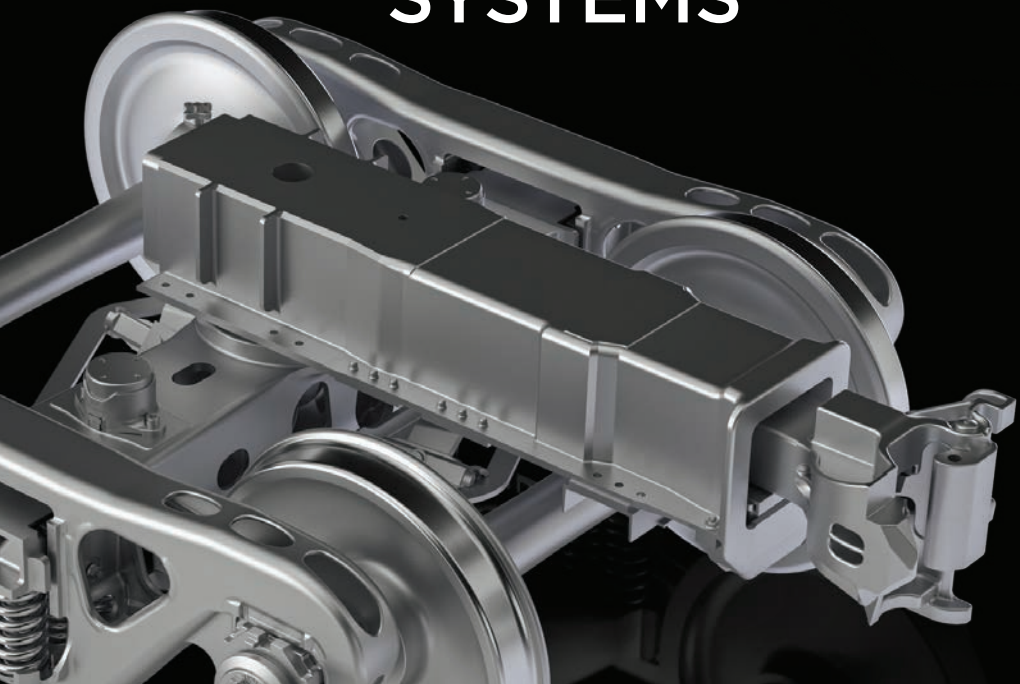

High reliability bogie systems

Around the globe, Amsted Rail bogies routinely exceed the million-mile barrier, even in the harshest operating environments. Our proprietary designs maximize stability and longevity while delivering increased payload and utilization.

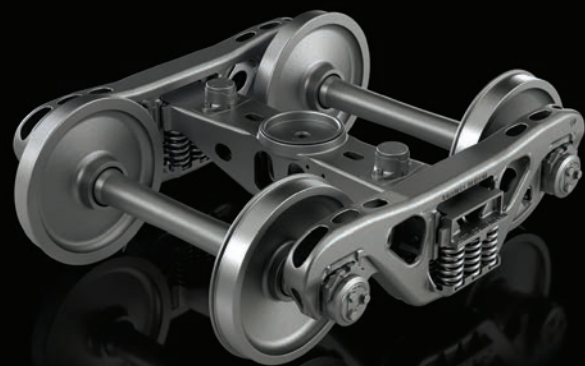

Rugged end-of-car systems

Built to take a beating, Amsted Rail end-of-car systems deliver powerful protection that can withstand virtually all the hits. In the end, it pays off in lower maintenance costs, reduced downtime and extended service life.

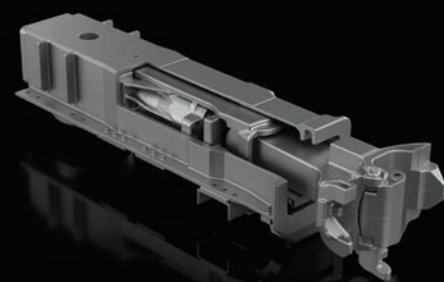

Dependable braking systems

Amsted Rail delivers the broadest array of advanced braking equipment. Each component meets the exacting specifications demanded by the rigors of today's freight wagon and train operational environments.



Durable locomotive solutions

Amsted Rail locomotive components can take on the heaviest loads under the most extreme conditions. Even today, nearly every train in service relies on our proprietary locomotive draft gear design to keep the train on track and moving.



HIGH PERFORMANCE RAIL SOLUTIONS FOR THE TRANSIT INDUSTRY

By combining our world-class expertise in the global freight rail market with the addition of service-proven General Steel Industries (GSI) truck designs, Amsted Rail is uniquely positioned to serve the transit industry.

Broad range of capabilities

From advanced dual suspension systems, axles and bearings, to end-of-car components designed for intercity and commuter cars, Amsted Rail is your single-source resource for precision-engineered railcar solutions.

State-of-the-art testing

Amsted Rail is one of the few companies capable of providing complete transit truck assembly testing, assuring unmatched reliability and satisfying the most demanding specifications.

Surpassing industry standards

Amsted Rail is committed to delivering the highest performance transit solutions. That's why our designs surpass CFR, FRA, PRIIA and APTA standards.

Full parts catalog

To minimize downtime and keep your passengers on the move today and tomorrow, we make sure you have a full catalog of maintenance parts to get the job done.

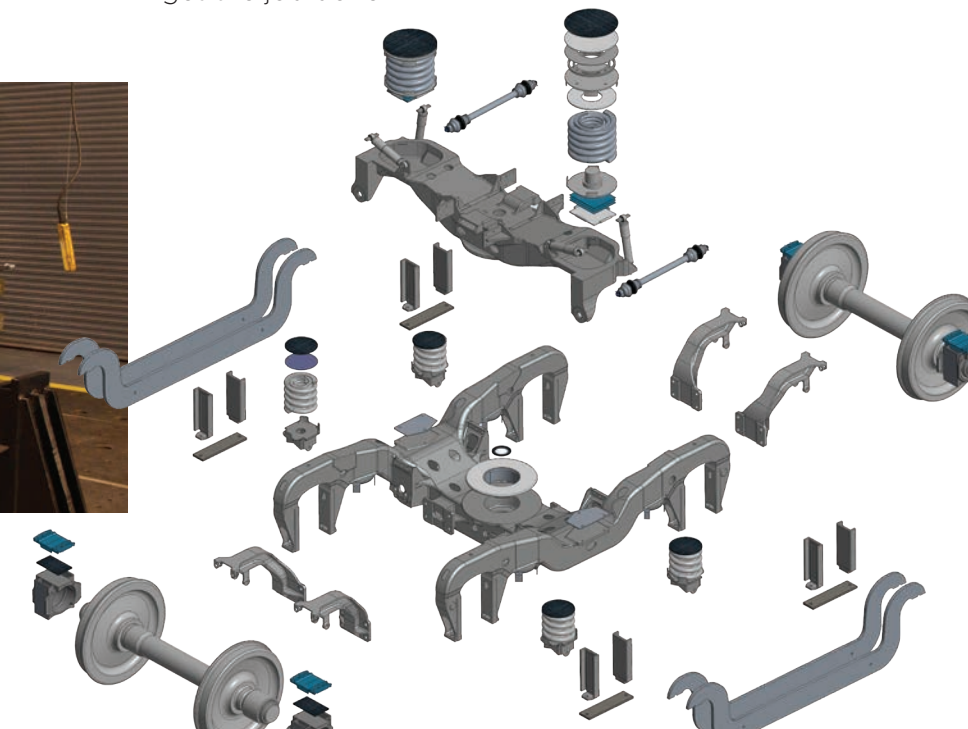
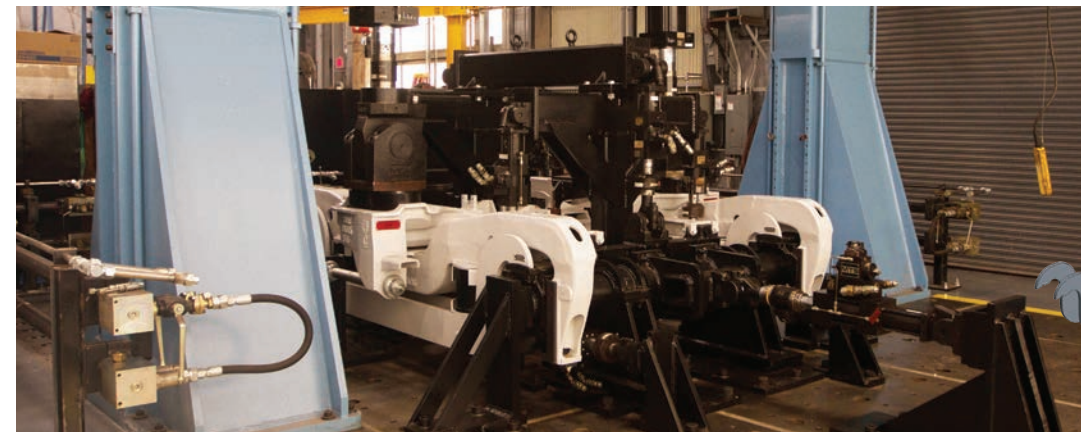
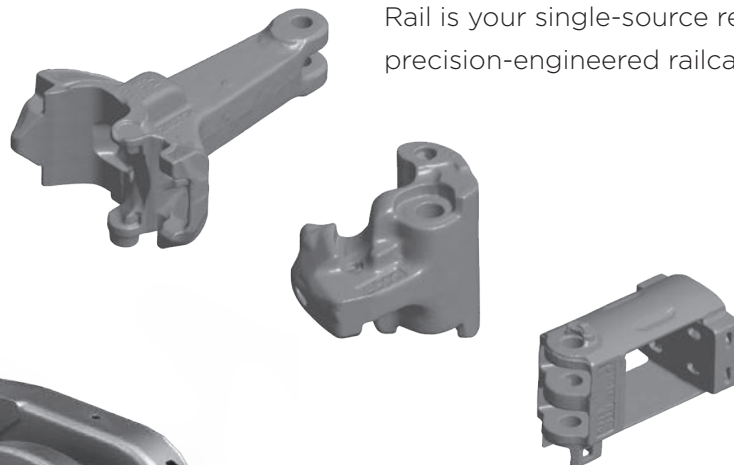
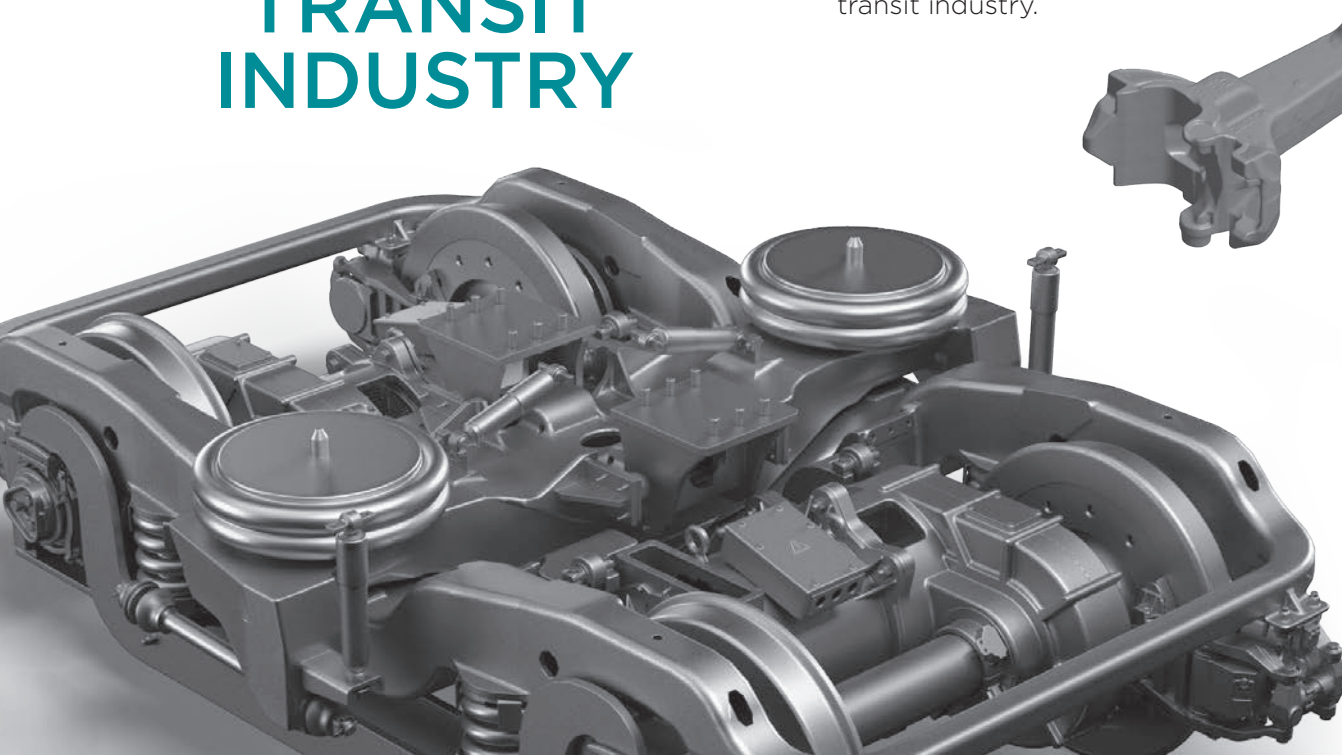

THE NEXT GENERATION OF FREIGHT RAIL TELEMATICS

As an IoT telematics solutions company, Amsted Digital Solutions (ADS) is uniquely focused on providing an end-to-end, fully integrated platform to track, trace and monitor unpowered asset segments around the world.

TANK TEMPERATURE THRESHOLD EXCEEDED

Temperature rise of 3°F per hour
 Asset: ADS 010234
 Fleet: ADS
 Date: 2019/02/03 10:02:45 AM
 City: 4 miles NW of Yuma, AZ
 Location: 32.877444, -114.915820

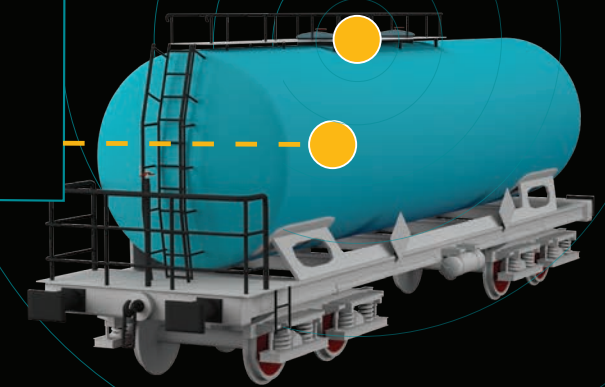

The latest IoT technology

Amsted Digital Solutions employs a combination of high-performance, ultra-low-power sensors, powered by our cloud-based Supply Chain Visibility™ platform, to convert raw data into actionable intelligence and predictive analytics.

Unmatched durability and safety

Our hermetically sealed gateways and sensors perform even in the most extreme climate conditions. ADS is an ISO 9001:2015 Certified Company and our products are Intrinsically safe to C1D1, IECEx, and ATEX Zone 0 (1G) & 20 (1D) - the highest safety rating available among telematics providers globally.



Greater visibility, greater productivity

ADS enhances fleet visibility and productivity by better optimizing asset utilization, status and health. The only telematics solution designed by a company that understands the demanding operations and harsh environments of freight rail, ADS is helping create the IoT hubs of tomorrow.



We see strategy at every coordinate





IMAGINE
HOW FAR
WE CAN
TAKE YOU

At Amsted Rail, our mission is simple. By infusing a culture of innovation throughout our company, Amsted Rail is leading the way in developing new products, new technologies and new inroads in digitalization that are driving change and moving the industry forward.

With dedicated employees worldwide and a global network of state-of-the-art manufacturing facilities, Amsted Rail is transforming the most promising ideas from the drawing board to test facilities, right to your railcar. We're designing smart solutions to help you better prepare for the challenges ahead – whether you're a railcar builder, fleet owner, railroad or leasing company.

We're excited about what's around the next corner and the new directions we can take you. Thanks to a century-long heritage of excellence and a commitment to continued innovation, you can depend on Amsted Rail to be here for the long haul.

Learn more about our performance-driven solutions:

Amsted Rail (Freight/Transit)

amstedrail.com

Amsted Digital Solutions

amsteddigital.com

Amsted Industries

amsted.com

PART OF
**DIVERSIFIED
MANUFACTURER**
**AMSTED
INDUSTRIES**

Amsted Rail is part of Amsted Industries, a diversified global manufacturer of highly engineered industrial components serving primarily the railroad, vehicular, construction & industrial and transport markets.

Amsted Industries is meeting the growing needs of a global market and we're proud to be a leader in each of the market segments we serve. A multi-billion dollar diversified global manufacturer, Amsted Industries is privately held and employee-owned, which allows employees to share in its future success.



Overview of product offerings

Railroad

- Bogie systems
- End-of-car systems
- Brake systems
- Asset monitoring systems
- Locomotive components

Vehicular

- Piston pins and powder metal parts
- Transmission and steering components
- Lightweight aluminum hubs
- Plastic interiors

Construction & Industrial

- Evaporative coolers

Transport and General Industries

- Sealing solutions





FREIGHT | TRANSIT | DIGITAL